

SYBERVISION 2000

THE NEUROPSYCHOLOGY OF
Self-Discipline

S T U D Y G U I D E

Steven A. DeVore
President
SyberVision 2000

SYBERVISION 2000
The Leader in Personal Achievement Technology

Copyright © 2002

SYBERVISION 2000
1627 North Mountain Oaks Drive
Orem, Utah 84097
Phone 1.800.275.6940 • Fax 1.801.327.0572
www.sybervision2000.com

All rights reserved. This program or any part thereof may not be reproduced in any form whatsoever without the prior written permission of SyberVision 2000 except in the case of passages used in articles for review.

CONTENTS

Session

Title

Click on Title to Navigate to Session

<i>Intrc</i>	<u>How to Use Your Neuropsychology of Self-Discipline Study Guide and Audio</u>
<i>I</i>	<u>The Neuropsychology of Self-Discipline: Your Master Key to Achievement</u>
<i>II</i>	<u>A Profile of Success: The 10 Dominant Characteristics of a Self-Disciplined Achiever</u>
<i>III</i>	<u>The Fire That Burns Deep Within: The 7 Steps to Developing Iron-Willed Discipline</u>
<i>IV</i>	<u>The Power of Purpose: Determining What You Really Want to Achieve</u>
<i>V</i>	<u>The Magic of Mentors: How to Learn and Draw Inspiration From Models of Success</u>
<i>VI</i>	<u>The Magnificent Obsession: How to Transform Your Dream Into a Sensory-Rich Vision of Achievement</u>
<i>VII</i>	<u>Power Planning: How to Turn Your Dream Into a Step-By-Step Blueprint of Success</u>
<i>VIII</i>	<u>The Time Connection: The Seasoning of an Achiever</u>
<i>IX</i>	<u>Mega Learning: How to Master the Knowledge and Skills You Need to Achieve Your Goals</u>
<i>X</i>	<u>Vision Quest: Winning Through Persistence and Perseverance</u>

HOW TO USE YOUR NEUROPSYCHOLOGY OF SELF- DISCIPLINE STUDY GUIDE AND AUDIO

This personal Study Guide has been designed to assist you in using the audio sessions and worksheets to learn the process behaviors, and principles contained in The Neuropsychology of Self-Discipline.

PROGRAM GOAL

The major goal of The Neuropsychology of Self-Discipline is to introduce you to a scientifically advanced, easy-to-learn system through which you can become a self-disciplined achiever.

PROCESS

This learning system involves a variety of modes of learning and practice to keep you motivated and increase the likelihood that you will successfully achieve your goal of developing self-discipline. You will be reading through the Study Guide, listening to the narration, practicing on the worksheets in the Study Guide and writing your goals and progress toward those goals. You may, of course, listen to the audio again and again to glean any additional information and guidance necessary to make the principles contained in this program a permanent part of your daily life.

There is a section of your Study Guide which corresponds to each of the program's ten audio sessions. For example, Session III of the Study Guide "The Fire That Burns Deep Within: The Seven Steps to Developing Iron-Willed Discipline" corresponds with audio Session III of the same title. You can listen to each audio session by clicking on the hyperlink for that session in each "Practice" section of this Study Guide.

TERMS USED IN THIS PROGRAM

Some terms you will hear and see in this program may be new to you. A couple of the most unusual ones, and how they will be used, are:

NEUROPSYCHOLOGY—a science that studies the relationship between the brain, nervous system and behavior.

SELF-DISCIPLINE—your ability to work systematically toward a desired goal until it is achieved.

STUDY GUIDE FORMAT

In each Study Guide section, there's a combination of explanations and step-by-step instructions for mastering the material presented. Each section is divided into the following components:

OBJECTIVES: A description of the behaviors and skills you will have mastered when you apply the instructions in the audio and the practice in your Study Guide.

BACKGROUND: A statement of the importance of this session and a summary of the main points included in the audio instruction and the Study Guide practices.

PRACTICE: Written exercises that will help you learn the new information and practice the skills that will enable you to produce the behavior and skills listed in the objectives. You can type your answers into the blank space provided after each written exercise. You can also launch the audio from within the Practice section.

POINTS TO REMEMBER: A summary of the most important ideas you gained from the audio instruction.

PROGRESS CHECK: A written exercise or activity that will allow you to measure how well you learned the principles and skills practiced in each session. The Progress Check is designed to give you feedback on your performance so you can feel good about what you accomplished, and, if appropriate, continue to strive toward your goal.

HERES WHAT TO DO

1. Scan the title of each audio session.
2. Scan the Table of Contents of the Study Guide.
3. Set aside a specific block of time each day to work through the audio and exercises. This is your investment in you, so keep the agreement of the time.

4. For each session you will follow a similar pattern of working through the Study Guide, listening to the audio, and doing the Practices. This is the sequence you will follow:
 - a. Read the Objectives.
 - b. Read the Background statement.
 - c. Listen to the audio.
 - d. Complete the worksheets as instructed in the Practice section.
 - e. Review the Feedback on the Practice, if appropriate.
 - f. Do the Progress Check.

5. You will be asked to provide written responses to questions in this Study Guide. You can type in your the responses from your computer keyboard where there is an underline mark in the answer box or you can print the study guide and hand write in the responses. If you type in your responses, be sure to save your work after each session.

There are some forms within the study guide that you must print in order to complete. This will be indicated on the individual forms.

6. When you have completed each Session, schedule a time when you will work through the next Session.

SESSION I

THE NEUROPSYCHOLOGY OF SELF-DISCIPLINE: THE MASTER KEY TO ACHIEVEMENT

OBJECTIVES

At the end of this session you will be able to:

- *Define self-discipline*
- *Describe the problems associated with a lack of self-discipline*
- *Describe the benefits of being self-disciplined.*

BACKGROUND

Your motivation to participate in this program probably comes from a need or desire to learn how to develop self-discipline—the ability to mobilize yourself and your talents to achieve what you want to achieve no matter how long it takes or how difficult it is to accomplish. At this point you may be acutely aware of the problems associated with the lack of self-discipline. Lasting success without sustained effort, planning, the seasoning of time and persistence is not possible. Shortcuts and success gimmicks lead only to mediocrity, disappointment, and failure.

Self-discipline is the master key to success. With it, you can accomplish everything. Without it, nothing worthwhile or lasting can be achieved.

By incorporating the research of the world's top research scientists into an effective, easy-to-understand and apply program, *The Neuropsychology of Self-Discipline* enables you to learn the skill of self-discipline.

The benefits of being self-disciplined might seem obvious, however we may have thought of some you may have not yet considered. These will be described on the audio and later you will personalize them to meet your own needs. Review this list to dwell on the positive outcomes that will be in store for you:

- Self-discipline is a skill that can be learned and converted into a habit.
- With self-discipline you can accomplish anything you desire. Nothing humanly possible will be impossible for you when you are self-disciplined.

- Self-discipline will increase your self-confidence and empower you with determination, intestinal fortitude, and strength.
- Self-discipline will give you a new passion for life. You will become more energetic and have more of a drive to achieve.
- Self-discipline will make you sought after as a leader – a role model for others to emulate and respect.
- Self-discipline will sharpen and refine your thinking and analytical abilities.
- Self-discipline will magnify your creativity. When your limitations are eliminated, innumerable possibilities and ideas continually flood your imagination.

This list of benefits must excite your thinking as to what you will achieve in this program! Now, proceed to the Practice and follow the instructions there.

PRACTICE

1. Re-read the objectives for this session.
2. Listen to the Session I narration, "Self-Discipline: Your Master Key to Achievement."

3. After you have listened to the session, use the space provided to write a brief description what self-discipline means to you.

4. In your own words write a brief statement of the problems associated with the lack of self-discipline.

5. Now for the good part! Write five benefits of you will derive from developing self-discipline.

1. _____

2. _____

3. _____

4. _____

5. _____

POINTS TO REMEMBER

- Talent, education, and intelligence are not the sole keys to success.
- Self-discipline is a skill that can be learned.
- Excellence takes time
- Self-discipline unlocks your innate power to achieve.

PROGRESS CHECK

1. Write a brief statement about the most significant problem you are now experiencing due to a lack of self-discipline.

2. Describe the least self-disciplined person you know and analyze his/her lack of success.

3. Now, list some of the benefits you will experience when you develop self-discipline.

ANSWERS TO PROGRESS CHECK

SESSION I

You are the best judge of how well your responses meet the objectives for this Session. If you are clear about one problem area you can eliminate through application of self-discipline, and anticipate realizing significant benefits from the program, you are ready to move on. Now, schedule the time to work on Session II.

SESSION II

A PROFILE OF SUCCESS: THE 10 DOMINANT CHARACTERISTICS OF A SELF-DISCIPLINED ACHIEVER

OBJECTIVES

At the end of this session you will be able to:

- *Describe the ten dominant characteristics of the self-disciplined achiever.*
- *Compare your current behavior against the model to establish areas where you might desire change.*

BACKGROUND

People who have achieved their goals become inspirational examples or role models for others to follow. How they achieved their goals, the strategies, skills, thinking and behavioral patterns they used become blueprints for people who want to achieve what the model achieved.

Models of achievement blaze the trail of possibility for us—breaking down the barriers of impossibility. We think, “If he or she did it, then so can I.”

In this Session, we have identified the 10 dominant characteristics that mark self-disciplined high achievers. These are the behaviors others learned in order to accomplish their goals in all areas of life. They are deeply ingrained, positive acquired characteristics which are the product of continued success.

In developing the model, the criterion we used was excellence in their chosen field, whether sports, business, entertainment, law, architecture. The characteristics we note are not specific to any one profession or field of endeavor.

Once you become familiar with the characteristics of the self-disciplined high achiever, you’ll be able to adapt your own life to include those positive values.

PRACTICE

1. Listen to audio Session II, "A Profile of Success: The 10 Dominant Characteristics of a Self-Disciplined Achiever." On the form below, as you listen, list the ten dominant characteristics as they are described.

1. _____
2. _____
3. _____
4. _____
5. _____
6. _____
7. _____
8. _____
9. _____
10. _____

2. The Personal Assessment Form below lists the 10 characteristics of the self-disciplined achiever. Each characteristic is presented in the same order as it is on the audio. Each is graded on a scale of one through seven. Read all the characteristics listed on the following worksheet first. Do not mark the form at this time, just review the characteristics listed.
3. Listen again to the 10 characteristics presented on audio Session II. As you listen to the characteristics being described, contrast and compare where you currently stand in relation to the described characteristics, behaviors and habits. Use the rating table as a tool for personal measurement and insight. As you listen to each description, think in terms of "I am more like the positive description" or "I am more like the negative description." Determine the degree to which you currently exhibit the habit or behavior. Then type the appropriate number on the scale that corresponds to your response. Your score will be automatically computed.

PERSONAL ASSESSMENT FORM									
(-)								(+)	Score
1. Weak sense of purpose	1	2	3	4	5	6	7	Strong sense of purpose	<u>0</u>
2. Negative role models	1	2	3	4	5	6	7	Seeks out positive mentors	<u>0</u>
3. Images of failure	1	2	3	4	5	6	7	Sensory-rich vision	<u>0</u>
4. Neg. Sensory Orientation	1	2	3	4	5	6	7	Positive sensory orientation	<u>0</u>
5. Crippling self-doubt	1	2	3	4	5	6	7	Strong belief in self	<u>0</u>
6. Sense of disorganization	1	2	3	4	5	6	7	Ability to plan, organize	<u>0</u>
7. Little value on education	1	2	3	4	5	6	7	Acquires learning, skills	<u>0</u>
8. Impatient – “quick fix”	1	2	3	4	5	6	7	Knows value of patience	<u>0</u>
9. Gives up easily, quitter	1	2	3	4	5	6	7	Perseverance	<u>0</u>
10. Work is burden/hardship	1	2	3	4	5	6	7	Work is pleasure/play	<u>0</u>
Total								0	

4. Once you have completed the Personal Assessment Form, your total score will be automatically calculated. If you scored between 10 and 45, you will benefit greatly from this program and the attitudes it will help you develop. If you scored between 50 and 60, this program will help you sharpen your already strong self-discipline habits and attitudes. If you score above 60, you will still benefit from the techniques we offer in this program.

POINTS TO REMEMBER

- The key to the Self-Assessment process is honesty.
- Developing the skill of self-discipline is a dynamic process of self-discovery and self-creation.

PROGRESS CHECK

When you have completed the Practice exercises, you will have fulfilled the criteria of the state objectives for this session.

SESSION III

THE FIRE THAT BURNS WITHIN: THE SEVEN STEPS TO DEVELOPING IRON-WILLED DISCIPLINE

OBJECTIVES

At the end of this session you will be able to:

- *Define the components of a successful motivational system.*
- *Describe the effects of sensory vision on emotion.*
- *Describe the effects of emotion on self-discipline.*
- *Explain the scientific basis for self-discipline.*

BACKGROUND

In Session III you will learn the scientific basis for self-discipline. You'll learn how the fire that burns deep within the self-disciplined achievers you admire and wish to emulate can be acquired through an understanding of how the brain works and how the brain's power can be harnessed.

You'll learn that any motivational program that is not based on self-discipline but relies on greed, fear, or immediate gratification will fail.

You'll learn about brain function from researchers in neuropsychology to gain a deeper understanding of the way the brain and the mind combine to create human behavior. You'll learn how an understanding of brain function will help you control your emotional responses, turning sensory-rich images of achievement in emotional fuel to power your intellectually arrived at plans.

You'll learn the seven steps which author Steve DeVore discovered to be at the heart of self-discipline. You'll discover why the self-disciplined people you admire don't seem to know the meaning of the word "failure." You'll not only learn the truth of the axiom "experience is the best teacher" you'll learn how to use your experience as a feedback mechanism that keeps you pointing toward your goal of self-discipline.

PRACTICE

1. Look at the following graphic model of the seven keys which contribute to self-discipline.

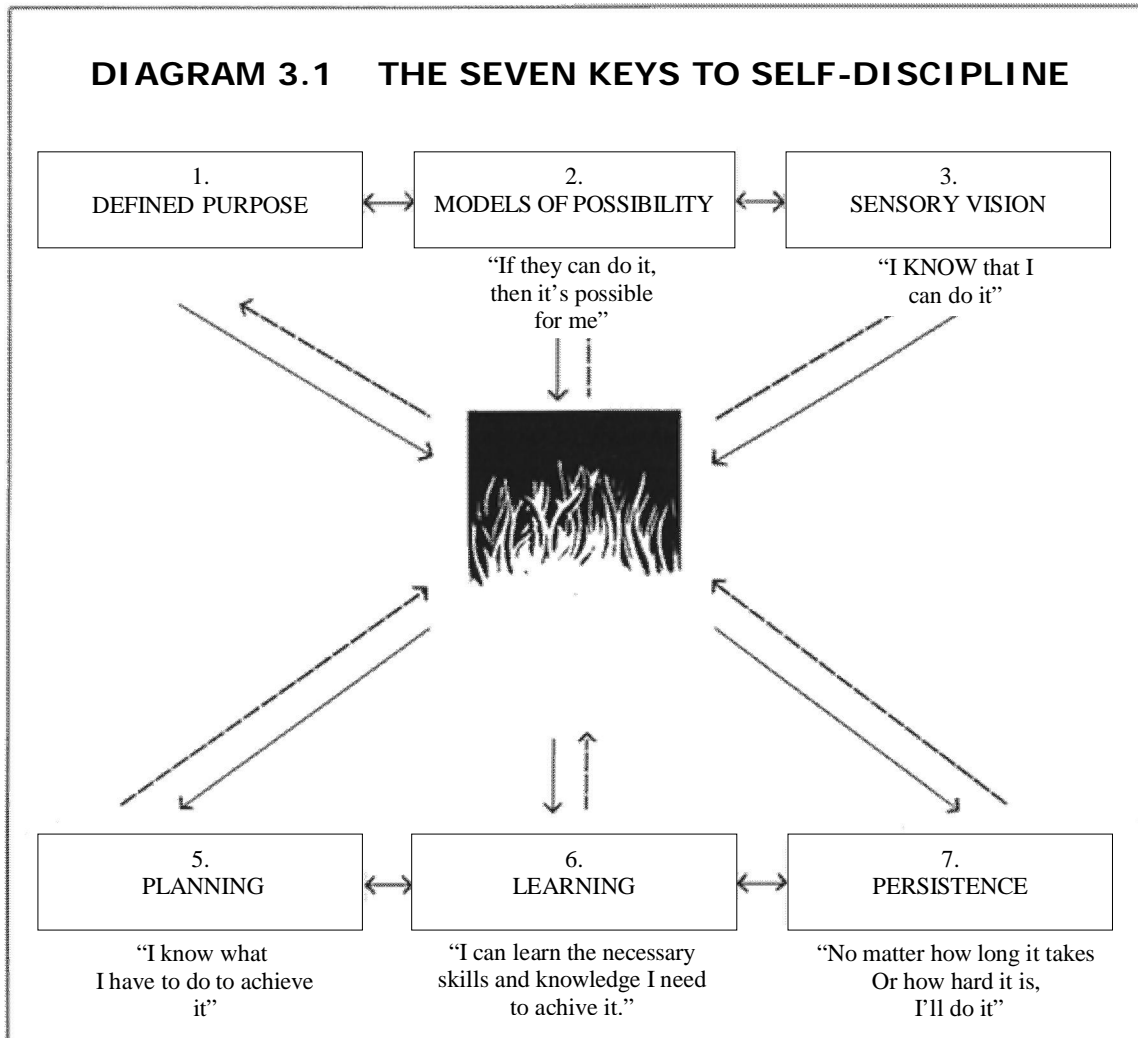

2. Describe in how each of the following fuels and reinforces self-discipline.

Purpose:

Other Achievers:

Sensory-Rich Vision:

Emotion:

Planning:

Learning:

Persistence:

FEEDBACK ON PRACTICE, Session III

Check your answers with Diagram 3.1. Listen to the audio again if you wish to re-check your answers.

POINTS TO REMEMBER

- Emotion unchecked is wasted energy. Emotion harnessed is the fuel for self-discipline.
- Imagination and creativity are synonymous.
- Self-awareness alone is rarely sufficient to stimulate change.
- Self-discipline has a scientific basis in the structure and organization of the brain.

SESSION IV

THE POWER OF PURPOSE: DETERMINING WHAT YOU REALLY WANT TO ACHIEVE

OBJECTIVES

At the end of this session you will be able to:

- *Define "macro" and "micro" purpose.*
- *List the four steps involved in determining your macro purpose.*
- *Write a personal statement of purpose.*

BACKGROUND

Determining your purpose, what you want to achieve in life, can be a very difficult task. You have so many choices and opportunities, so many different directions you can go. It's wonderful to have so many choices, but sometimes it makes choosing what you really want to do—your true purpose—even more confusing.

Purpose is the cornerstone of self-discipline. With a clearly defined purpose you have a specific direction where to focus your energy.

In this Session, you will learn a four step process that will enable you to analyze the many options available to you and select the one major life's purpose you want, deep within your heart, to achieve.

This four step process, besides being a powerful tool in determining your major life's purpose, will help you in making any kind of decision—from the smallest to the most important.

With a clearly defined purpose, you're well on your way to becoming a self-disciplined achiever. You've discovered what you really want to do with your life. You've laid the foundation upon which the power of self-discipline is built.

PRACTICE

1. Listen to Session IV, "The Power of Purpose: Determining What You Really Want To Achieve."
2. As you have listened to the narrator describe "macro" and "micro" purpose, write in your own words a brief description of each.

Macro Purpose:

Micro Purpose:

3. When you are instructed to do so by the narrator, write in the space provided below each of your five wishes. Begin each wish with "I want..."

Wish One:

Wish Two:

Wish Three:

Wish Four:

Wish Five:

4. Select the one wish that is the most important to you. In the space provided below write a brief statement why the wish is the most important to you.

5. When instructed by the narrator, read the following biographical summary of Thomas Arnold:

Thomas Arnold (1795-1882). Some people are loved without being respected, and others are respected without being loved. Arnold of Rugby was loved by many – respected and admired by everyone who knew him. Born at Cowes, Isle of Wight, this great headmaster and scholar was educated at Winchester and at Oxford in England, where he distinguished himself in classics and history. He left Oxford in 1819, and after nine years of study and writing was elected headmaster of Rugby School. His powerful personality set its mark on the school from the first and made it great in a new sense. He was very religious and he inspired his boys with new and more serious ideals of scholarship and life.

He found time, too, during the 14 years of his headmastership, to publish sermons, an edition of the Greek historian Thucydides, and a history of Rome. In 1841 he was appointed professor of modern history

at Oxford but died the following year. He was buried in Rugby Chapel and his son Matthew wrote a beautiful eulogy about him on that occasion. Arnold was too forthright to be tactful in his dealings with boys or indeed with grown-up, but he always won their respect, and often their love by his high-minded attitude toward life and its responsibilities.

6. When instructed by the narrator, write in the space below your personal biographical statement.

**CREATIVE BIOGRAPHY
MY PERSONAL BIOGRAPHICAL STATEMENT**

7. When instructed by the narrator, write in the space below your personal statement of purpose.

<p>MY PERSONAL STATEMENT OF PURPOSE</p> <hr/>
--

POINTS TO REMEMBER

- An emotionally compelling purpose is the foundation of the power of self-discipline.
- Your statement of purpose should reflect your inner-most desire –what you want to achieve in life above all else.
- Your written statement of purpose can be as general as you want it to be. It is a focusing tool rather than a detailed blueprint of how you are going to achieve it.
- Give serious thought to the “Limitless Wishing” exercise. Do not approach it lightly. It is an integral part of this program.

PROGRESS CHECK

1. Without looking back at your notes, write a brief description of a “macro” purpose.

—

2. Without looking back at your notes, write a brief description of a “micro” purpose.

—

3. List the four steps involved in determining your personal purpose.

Step One: _____

Step Two: _____

Step Three: _____

Step Four: _____

SESSION V

THE MAGIC OF MENTORS: HOW TO LEARN AND DRAW INSPIRATION FROM MODELS OF SUCCESS

OBJECTIVES

At the end of this session you will be able to:

- *Describe and discriminate the difference between the concepts of "indirect" and "direct" modeling.*
- *List the three sources where you can find indirect models.*
- *Describe the three sources where you can find direct models.*
- *Analyze and identify the strengths of your role models.*
- *Describe how to demystify models of achievement.*
- *Describe the process of character assimilation (acting "as if") and why it's important to achievement.*

BACKGROUND

People who have achieved what you want to achieve can serve as models of inspiration and learning. In this session, you will learn how to identify successful role models with whom you can identify, draw inspiration and learn.

Role models can inspire you with a sense of possibility—"if he or she can do it, then it's possible for me." This sense of possibility is an essential emotional ingredient in developing the power of self-discipline. Role models also shorten your process of learning through trial and error. Through observation and analysis, you can identify and acquire the achievement behaviors exhibited by your role models.

PRACTICE

1. Listen to audio Session V, "The Magic of Mentors: How to Learn and Draw Inspiration from Models of Success."
2. As you hear the narrator describe the concepts of indirect and direct modeling, write in the space provided below a description of each.

Indirect Modeling:

Direct Modeling:

3. List three sources where you can locate models indirectly.

1. _____

2. _____

3. _____

4. List three sources where you can locate models indirectly.

1. _____

2. _____

3. _____

5. The Personal Assessment Form you used in Session II to compare your personal strengths and weaknesses against the model of self-discipline can be used as a source of analysis in determining the strengths and weaknesses of the models of achievement you choose to emulate. Below is an adaptation of that form.

MENTOR ASSESSMENT FORM

Name of Model _____

This model inspires me to: _____

Rate the model on the following characteristics:

1. Weak sense of purpose	1	2	3	4	5	6	7	Strong sense of purpose
2. Negative role models	1	2	3	4	5	6	7	Seeks out positive mentors
3. Images of failure	1	2	3	4	5	6	7	Sensory-rich vision
4. Neg. Sensory Orientation	1	2	3	4	5	6	7	Positive sensory orientation
5. Crippling self-doubt	1	2	3	4	5	6	7	Strong belief in self
6. Sense of disorganization	1	2	3	4	5	6	7	Ability to plan, organize
7. Little value on education	1	2	3	4	5	6	7	Acquires learning, skills
8. Impatient – “quick fix”	1	2	3	4	5	6	7	Knows value of patience
9. Gives up easily, quitter	1	2	3	4	5	6	7	Perseverance
10. Work is burden/hardship	1	2	3	4	5	6	7	Work is pleasure/play
11. Work is burden/hardship	1	2	3	4	5	6	7	Work is pleasure/play
12. _____	1	2	3	4	5	6	7	_____
13. _____	1	2	3	4	5	6	7	_____
14. _____	1	2	3	4	5	6	7	_____
15. _____	1	2	3	4	5	6	7	_____

The model's primary strengths are:

The models primary weaknesses are:

I can learn the following skills and positive behaviors from the model:

6. Print and use the Model Assessment Form as a template to identify and profile the strengths and weaknesses of your chosen models, and what you can learn from them. In the blank spaces (characteristics 11 through 15) fill in any characteristics that are not provided for on the form.

7. After you listen to the narrator describe how to demystify models, list the three ways you can learn to identify with models of great achievement.

1. _____

2. _____

3. _____

POINTS TO REMEMBER

- Search for models who have already achieved your purpose. Learn how they achieved their purpose and use what you learned as a blueprint for your own behaviors.
- To acquire a positive characteristic simply role play or act as if you already possessed the characteristic. If you do this consistently, over a period of time, the positive behavior will become a habit that replaces its self-defeating behavioral counterpart.
- You have inherent power not only to equal but to surpass the accomplishments of your role models.
- Your emotional reaction “If he or she did it, then it’s possible for me” is one of the master keys to developing your power of self-discipline. This emotion eliminates your self-imposed limitations and barriers. It is the most important realization you must make before you can achieve any worthwhile purpose.

PROGRESS CHECK

1. Write a brief statement about how models of achievement can give you a sense of possibility. Why is this sense of possibility so important to developing the power of self-discipline?

—

2. Without looking at your notes, describe how you can indirectly and directly find role models.

—

3. In your own words, describe how you can demystify role models.

—

4. Briefly explain why role playing or acting “as if” is an effective way to acquire desirable behaviors.

—

SESSION VI

THE MAGNIFICENT OBSESSION: HOW TO TRANSFORM YOUR DREAM INTO AN IMAGE OF ACHIEVEMENT

OBJECTIVES

At the end of this session you will be able to:

- *Describe how a sensory vision of purpose effects your ability to be self-disciplined.*
- *Translate your statement of purpose into a sensory vision.*
- *List and use the five daily guidelines for internalizing and emotionally reinforcing your sensory vision of purpose.*

BACKGROUND

So far you have identified your purpose (Session IV) and drawn inspiration and know-how from role models who have achieved the same or similar purpose (Session V). In this session, you will learn how to transform your purpose and sense of possibility into a specific, sensory detailed vision or goal. This vision of purpose, rich in imagination and emotion, will serve as the wellspring from which you will draw the necessary energy to relentlessly pursue your purpose over an extended period of time.

PRACTICE

1. Listen to the narrator on audio Session VI "The Magnificent Obsession: How to Transform Your Dream Into a Sensory-Rich Vision of Success."
2. When instructed to do so by the narrator, translate your statement of purpose into a Sensory Goal Statement. Use the space provided below. The statement should specifically state what you want to achieve, when you want to achieve it, and specify a measure to let you know when you have achieved it.

FORM 6.1
SENSORY GOAL STATEMENT

3. When instructed to do so by the narrator, print and complete the following "Vision of Achievement" form.

FORM 6.2
VISION OF ACHIEVEMENT

Insert role playing photographs of yourself having already achieved your goal or pictures of other people or symbols which represent your achieved goal.

4. When instructed to do so by the narrator, complete Form 6.3 'Positive Consequences Worksheet.'

FORM 6.3
POSITIVE CONSEQUENCES WORKSHEET
Write a list of all the advantages and rewards you will experience as a result of achieving your vision.

1. _____
2. _____
3. _____
4. _____
5. _____
6. _____
7. _____
8. _____
9. _____
10. _____

5. When instructed to do so by the narrator, complete Form 6.4 "Sensory Vision Worksheet."

FORM 6.4
SENSORY VISION WORKSHEET

Write a detailed description of the positive sensory impressions you will experience when your goal is achieved.

SIGHT: _____

SOUND: _____

FEEL: _____

TASTE: _____

SMELL: _____

EMOTION: _____

As the narrator describes the five guidelines for internalizing your vision of purpose, write each step in the space provided below.

1. _____

2. _____

3. _____

4. _____

5. _____

POINTS TO REMEMBER

The following points are important to you as you work to transform your purpose into an emotion-provoking, sensory-detailed vision of achievement.

- Your purpose is a general statement of what you would like to achieve. Your vision is your purpose translated into a specific goal that is rich in sensory imagery.
- The emotional by-product of a clearly defined, sensory-rich vision is a deep, compelling conviction that your purpose is obtainable. Sensory vision takes you from the feeling of possibility to a concrete belief that you know, deep in your heart and mind, that you can achieve your goal.
- The most important sensory images to dwell upon are the images of yourself reaping the rewards of your achieved vision.
- It is vitally important to work, on a daily basis, on transforming your vision into a passion for achievement.

PROGRESS CHECK

1. Without looking at your notes, write a brief description of how a clear, sensory vision effects your ability to be self disciplined.

2. Without looking at your notes, list the five daily steps involved in internalizing and reinforcing your vision.

1. _____

2. _____

3. _____

4. _____

5. _____

3. Check your answers in the Progress Check with the notes you made during the Practice.

SESSION VII

POWER PLANNING: HOW TO TURN YOUR DREAM INTO A STEP-BY-STEP BLUEPRINT OF ACHIEVEMENT

OBJECTIVES

At the end of this session you will be able to:

- *List the seven steps involved in building a visual planning network.*
- *Develop a visual planning network.*
- *Translate any task necessary to the fulfillment of your vision into a visual planning network.*

BACKGROUND

Once you have created the vision of what you want to achieve and developed the inner conviction that you can achieve it, the next step is learning how to translate your vision (and the tasks associated with it) into a specific step-by-step plan.

The ability to break a project down into its most basic parts and then systematically complete each part in logical order is one of the most important skills possessed by the self-disciplined achiever.

In this session, you will learn a simple yet powerfully effective system of planning—how to organize any task you want to accomplish into logical, easy to visualize steps. We call this planning process Visual Network Planning (VNP). VNP is applicable to every type of task or project. It will help you organize your personal resources, plan and schedule to meet critical deadlines, and control the quality of what you do.

VNP incorporates the best elements of two scientific project planning systems—Critical Path Methodology (CPM) and Program Evaluation Review Technique (PERT).

VNP is easy to learn and use. It is a tool that will dramatically improve your ability to start and successfully finish any project or task. Armed with the

power of planning, you will be able to transform your vision, step-by-step, into a successful reality.

PRACTICE

1. Listen to audio Session VII, "Power Planning: How to Turn Your Vision into a Step-By-Step Blueprint."
2. Study and review each of the following diagrams when you are instructed to do so by the narrator.

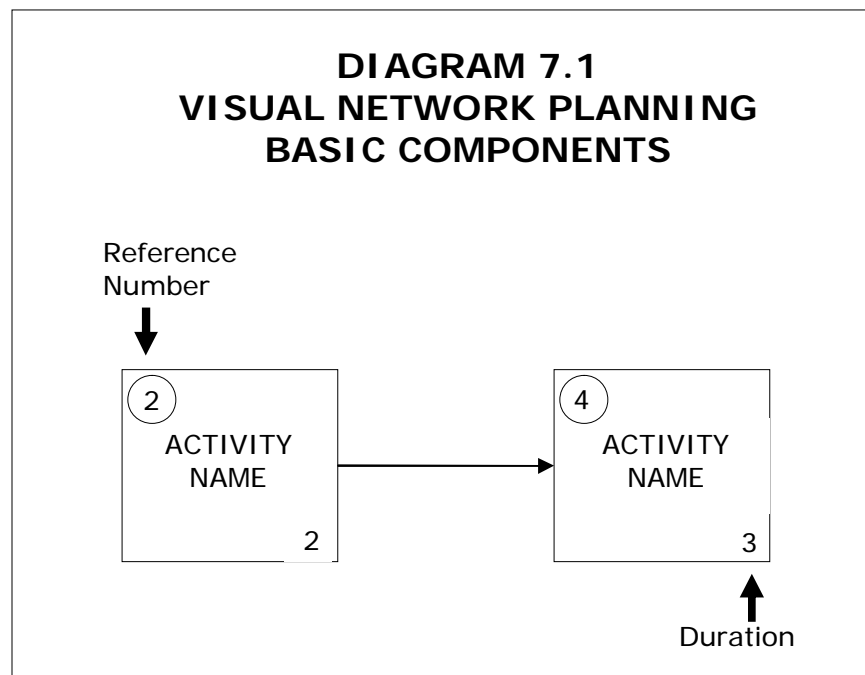

- An **ACTIVITY** is a step or task that must be completed if the plan is to be successfully completed. An activity is represented by a box which is **LINKED** to the next activity with a **LINE** and **ARROW**.
- Each activity takes a certain amount of time to complete. The time to complete an activity is called **DURATION**. Duration is listed in the bottom right hand corner of each activity box. Duration can be represented in minutes, hours, days, weeks, or years.
- A **NETWORK** is a group of interrelated and linked activities.

DIAGRAM 7.2 SIMPLE VISUAL NETWORK PLAN

Objective: Cook whole wheat cereal from scratch.

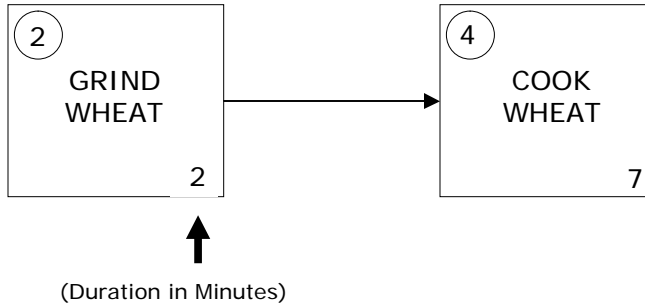

- Activity 2 is grinding the wheat.
- Activity 4 is cooking the wheat
- When Activity 2 has been completed, having taken two minutes, Activity 4 is ready to begin. Activity 4 takes seven minutes. Therefore, the entire plan shows that grinding the wheat preceded cooking the wheat and both activities require a total time span of nine minutes.

DIAGRAM 7.3 COMPLEX VISUAL NETWORK PLAN

Objective: Get the car and motorcycle out of the garage

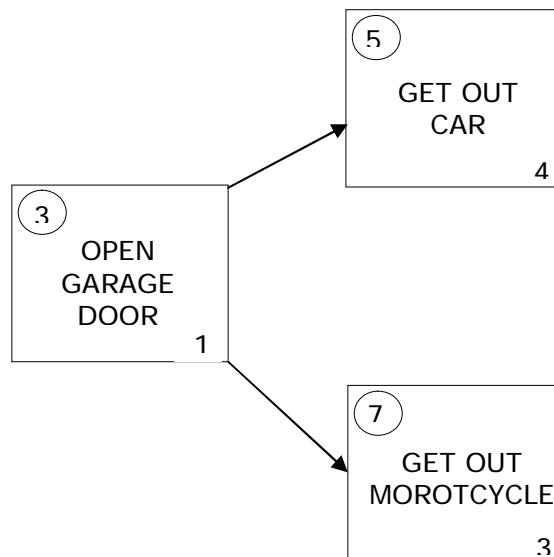

- Opening the garage door must be completed before the car and motorcycle can be taken out of the garage. Neither activity can begin until the garage door is opened.
- Activities 5 and 7 are not dependent on each other. They can be accomplished at the same time by two people, either of whom could have opened the garage door. Or, they each activity can be accomplished one at a time by one person in no specific order.

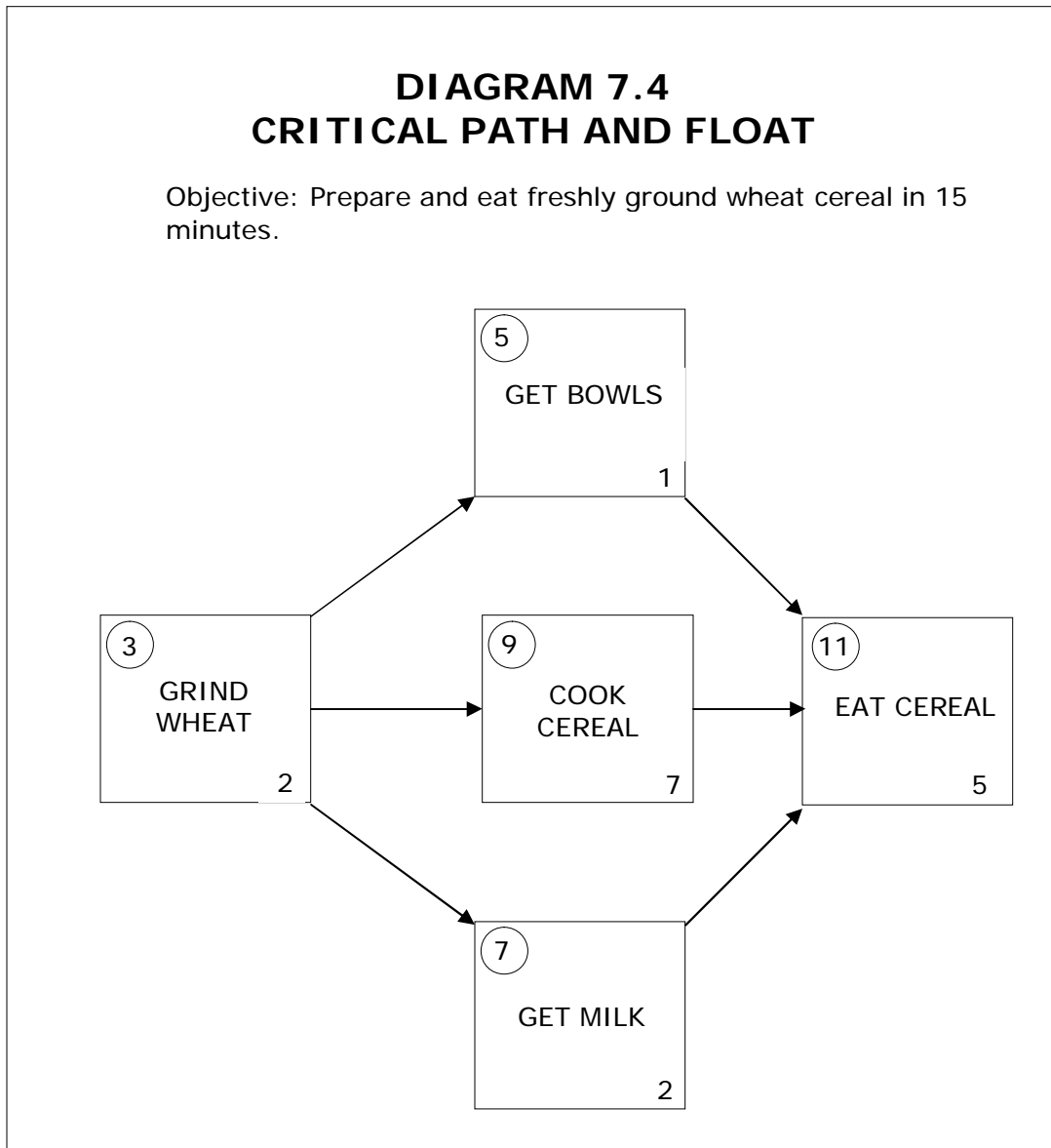

- At least one of the paths through the visual network will take longer than the others.

- The activities on the longest path must be accomplished on time if the project is to be completed on time. The longest path is known as the CRITICAL PATH. The activities on the critical path are called CRITICAL ACTIVITIES. Critical activities are vital to the success of the project.
- The NON-CRITICAL ACTIVITIES—those not on the critical path—can be delayed without affecting the end date or time. These activities have what is called FLOAT. Float is the amount of time they can be delayed without affecting the completion of the project.
- In the above plan, grinding the wheat, cooking the wheat, and eating the cereal take the longest amount of time and are thus on the critical path. Getting the bowls and milk can both be delayed without affecting the schedule. Therefore, they both have float.

DIAGRAM 7.5 SYBERVISION SYSTEMS AUDIO PROGRAM DEVELOPMENT VISUAL NETWORK PLAN

Objective: Develop within 33 weeks a thoroughly researched, high-quality audio self-improvement program with digital study guide.

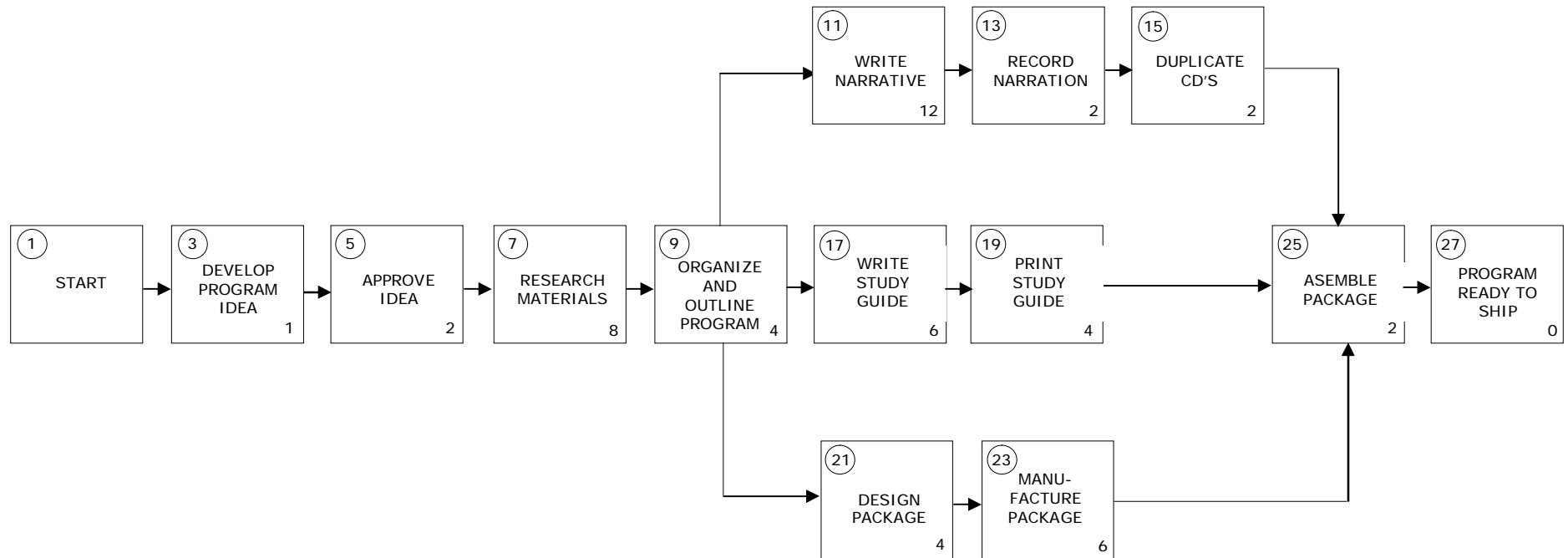
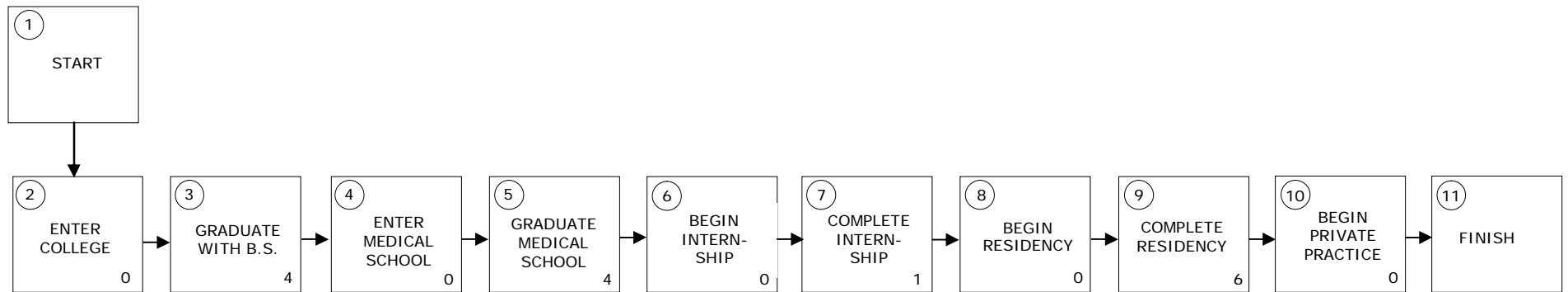

DIAGRAM 7.6 SAMPLE MACRO-EDUCATION PLAN

Objective: To become a neurologist.



3. Following is a listing of the seven steps involved in building a Visual Network Plan. Review each of the steps when instructed to do so by the Narrator.

THE SEVEN STEP VISUAL NETWORK PLANNING PROCESS

STEP ONE: Write your objective. Specify what you want to accomplish and when you want to accomplish it.

STEP TWO: Break your objective down into major steps or activities.

STEP THREE: Organize the activities in logical order.

STEP FOUR: Design a visual network.

STEP FIVE: Estimate how long each activity will take to complete.

STEP SIX: Determine the critical path and float.

STEP SEVEN: Assign calendar dates to each activity.

4. When instructed to do so by the narrator, develop on a separate sheet of paper a visual network plan that reflects the fulfillment of your vision.

POINTS TO REMEMBER

- The planning process you have learned can be applied to any project or task.
- Planning is a master skill of the self-disciplined. It is much easier to achieve your goals if you know precisely where you are going, the steps that will get you there and how long it will take you to achieve it.

PROGRESS CHECK

The completion of your personal Visual Network Plan satisfies the requirements of the Progress Check for this Session.

Now that you have learned to translate your vision into a master plan, schedule yourself to complete Session VIII.

SESSION VIII

THE TIME CONNECTION: THE SEASONING OF AN ACHIEVER

OBJECTIVES

- *List the three time management strategies used by most self-disciplined achievers.*
- *Define the concept of "seasoning."*
- *Define the concept of "time quickening."*
- *List the three major causes of procrastination.*
- *Describe the concept of "swiss cheesing."*
- *Perform the "unscheduling" exercise.*

BACKGROUND

In this session you will learn how self-discipline achievers use and manage time. Once the self-disciplined have a detailed plan, they put it into action. No matter how long it might take to achieve a goal, the self-disciplined achiever is not intimidated by the prospect of the length of time it will take to achieve it. You will learn how to use the strategies and techniques that enable the self-disciplined to pursue their vision with patience and sustained action. You will also learn how to overcome procrastination.

PRACTICE

1. Listen to Session VIII: "The Time Connection: The Seasoning of an Achiever."
2. As you listen to the narrator describe the three time management strategies, summarize each in the space provided below.

1. _____

2. _____

3. _____

3. Listen to the narrator describe the concept of “seasoning.” In the space provided below write a definition of “seasoning.”

4. Listen to the narrator describe the concept of “time quickening.” In the space provided below, write a definition of “time quickening.”

5. When described by the narrator, list the three major causes of procrastination.

6. When explained by the narrator, describe in the space below how to overcome procrastination.

7. Listen to the narrator describe the concept of “swiss cheesing.” In the space provided below write a definition of “swiss cheesing.”

8. When instructed by the narrator, use Form 8.1 to complete the Unscheduling exercise.

**FORM 8.1
UNSCHEDULING WORKSHEET**

	Sunday	Monday	Tuesday	Wednesday	Thursday	Friday	Saturday
6:00							
7:00							
8:00							
9:00							
10:00							
11:00							
12:00							
1:00							
2:00							
3:00							
4:00							
5:00							
6:00							
7:00							
8:00							
9:00							
10:00							

POINTS TO REMEMBER

- Achievement with excellence requires time and effort.
- Self-disciplined people are not intimidated by the thought of a long-term commitment to the achievement of a goal.
- The self-disciplined are not easily diverted from their goal-oriented activities. They know how to resist the temptations that would divert time and energy from the completion of their priority activities.
- Procrastination is usually the fear of failure rather than laziness.

PROGRESS CHECK

1. Write a brief description of how you will overcome the tendency to procrastinate.

—

2. Review the “Unscheduler Exercise” and use it often to schedule your priorities and time.

SESSION IX

MEGA-LEARNING: HOW TO MASTER THE KNOWLEDGE AND SKILLS YOU NEED TO ACHIEVE YOUR GOALS

OBJECTIVES

- *Determine the knowledge and skills you must learn to achieve your vision and purpose.*
- *Describe the relationship between your ability to learn and your belief in your ability to learn.*
- *Realize learning is a systematic, step-by-step process that requires time, patience, daily study, and application.*
- *Describe the concept of Mega-Learning and list the four steps involved in the process*
- *Understand the relationship between knowledge and creativity.*
- *List and describe the four step process of creativity.*

BACKGROUND

In this Session you will be introduced to a powerful learning system called Mega-Learning. This easy to understand and use system of learning will enable you to master the knowledge and skills critical to the achievement of your vision and purpose.

By understanding and applying the Mega-Learning system, you will have the confidence and ability to master any new subject matter or skill—irregardless of the complexity and difficulty of the information to be learned. The new knowledge and skills you acquire through Mega-Learning will serve as building blocks for increased creativity.

In this session you will also learn how to channel your new knowledge and skills into creative energy that will help you achieve your vision and purpose with excellence.

Ready to learn how to learn? Move along to the Practice section.

PRACTICE

1. Review your Practice and Progress Checks for each of the preceding sessions.
2. Listen to audio Session IX "Mega-Learning: How to Master the Knowledge and Skills You Need to Achieve Your Goals."
3. As you listen to the narrator explain how to determine the knowledge and skills you need to master, list the four recommended methods below.
 1. ____
 2. ____
 3. ____
 4. ____
4. Refer to Diagram 9.1 below as an example of a Visual Network Plan for learning.

DIAGRAM 9.1 VISUAL NETWORK PLAN FOR LEARNING

Macro-Objective: become a neurologist.

(Refer to Diagram 7.6 for a Visual Network Plan for becoming a neurologist)

DIAGRAM 7.6

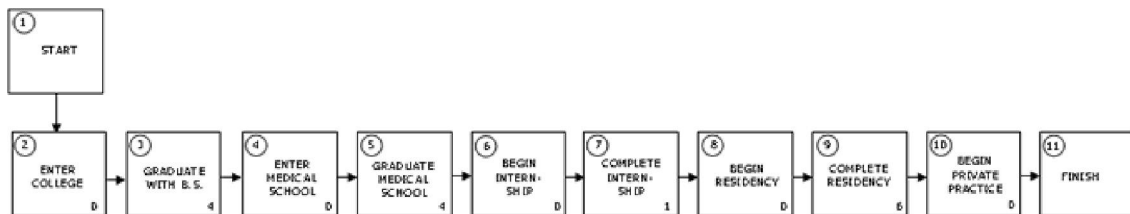

Micro-Objective: Graduate in pre-medicine in 4 years with a minimum 3.5 grade point average.

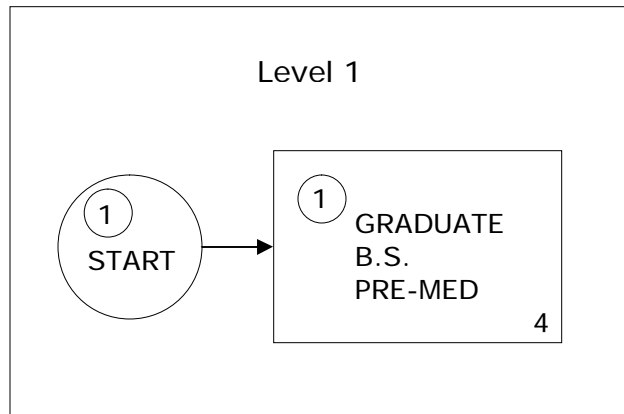

Level 2 Undergraduate Core Courses to Complete
 Duration: Each Activity Box = 1Quarter or 3 Months

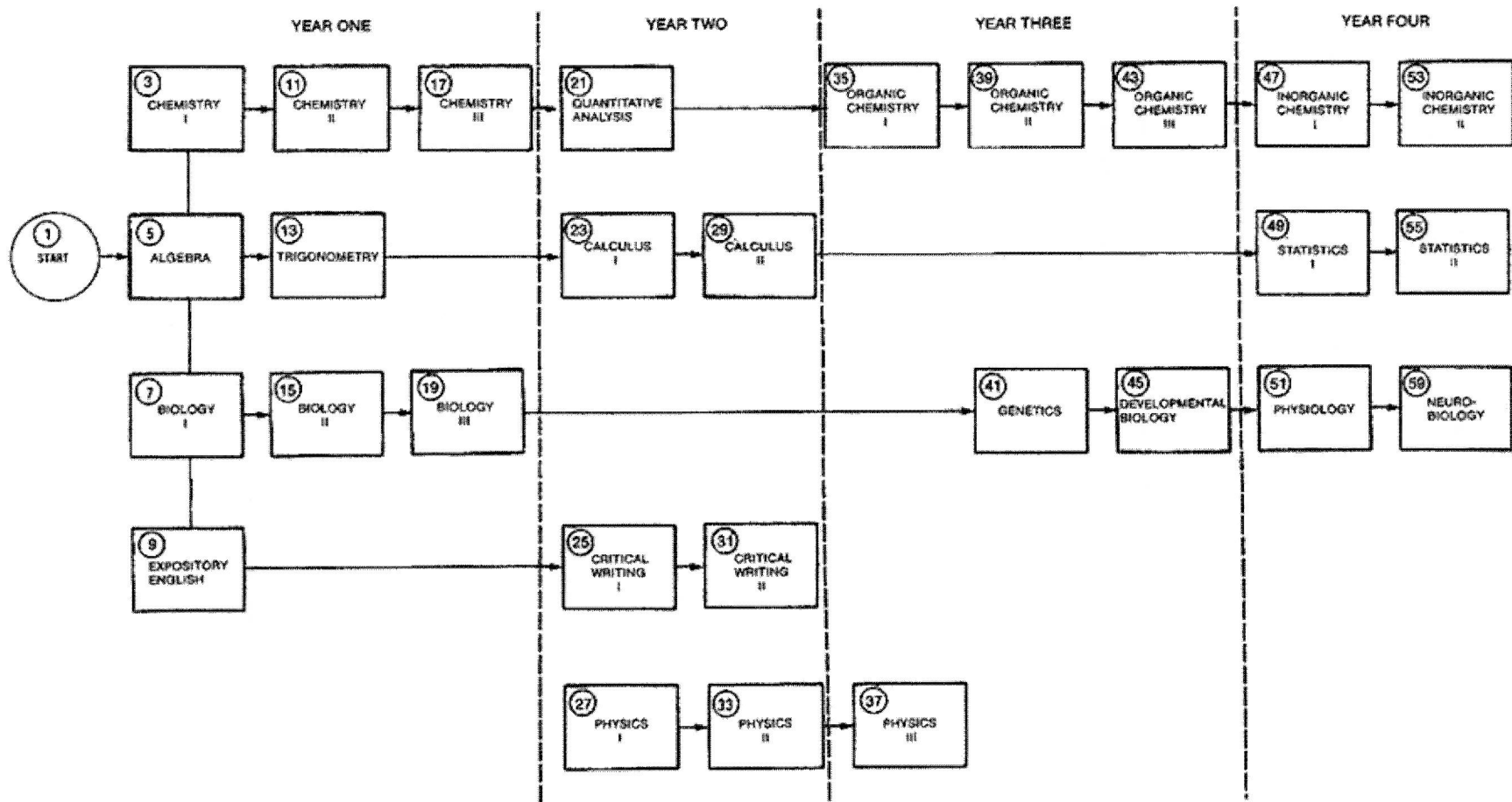

5. As the narrator describes how to overcome the barriers to learning complex material, describe the relationship between self-belief and your ability to learn new knowledge and skills.

6. While you listen to the narrator describe the Mega-Learning system, list each of the system's four steps.

1. _____

2. _____

3. _____

4. _____

7. After the narrator discusses learning and creativity, write a brief summary describing the relationship between knowledge and creativity.

8. Listen to the narrator describe the four step process of creativity and list each step in the space provided below.

1. _____

2. _____

3. _____

4. _____

POINTS TO REMEMBER

The Four Step Mega-Learning System

STEP ONE: Recognize your need to learn the new knowledge or skill. "It is a pre-requisite to the achievement of my purpose and vision. Without it, I cannot achieve what I want. With it, I can."

STEP TWO: Relate the learning to the achievement of your goal. How will it help you achieve your purpose and vision?

STEP THREE: Relate the principles of what you are learning to you own experience. Translate "X's" and "Y's" into apples and oranges—the abstract into concrete things and images drawn from your own experience.

STEP FOUR: Make permanent what you learn through experimentation and application. Immediately find a practical use for your new knowledge or skill and then apply it repeatedly in real life situations.

- Learning is not memorizing facts. It is understanding new principles and applying them in your day-to-day activities.
- Ninety percent of learning is your belief in your ability to learn. You can learn anything you believe you can learn.
- Learning new knowledge and skills requires time, patience, and day-to-day study, application and experimentation.
- Most people confuse their inability to learn certain subject matter with aptitude rather than attitude and application.
- Successful learning of new knowledge and skills breeds confidence in your ability to tackle and learn more new knowledge and skills.
- Knowledge and skill seasoned with experience is the fuel of creativity.

PROGRESS CHECK

1. Without looking back at your notes, list and describe each of the four steps of the Mega-Learning system.

1. _____

2. _____

3. _____

4. _____

2. Develop a Visual Network Plan for the major knowledge and skills you need to master in order to achieve your goals. Refer to session VII and Practice exercise four in this Session.

3. Schedule your time to complete Session X.

SESSION X

VISION QUEST: WINNING THROUGH PERSISTENCE AND PERSEVERANCE

OBJECTIVES

At the end of this session you will be able to:

- *Define persistence and perseverance.*
- *List and describe the five keys to developing persistence and perseverance.*
- *List and describe the five steps involved in turning setbacks, discouragement, and failure into positive learning experiences.*

BACKGROUND

Persistence is never giving up—never quitting—working relentlessly until your vision is achieved not matter how long it takes. Perseverance is persisting in spite of opposition, setbacks, and pain. It is learning from your failures and applying what you learn to the pursuit of your vision.

In this session, you will learn how to develop persistence and perseverance through understanding and applying five simple principles. You will also learn how to turn setbacks and failures into positive learning experiences that will strengthen your character, solidify your will and get you closer to the realization of your vision and purpose.

PRACTICE

1. Listen to audio Session X, "Vision Quest: Winning Through Persistence and Perseverance."
2. After listening to the narrator describe the principles of persistence, clearly define in your own mind the difference between persistence and perseverance.
3. While you are listening to the narrator describe the five keys to developing persistence and perseverance, list each of the keys in the space provided below.

1. _____

2. _____

3. _____

4. _____

5. _____

3. While you are listening to the narrator describe the guidelines for turning adversity into opportunity, list each of the five guidelines in the space provided below.

1. _____

2. _____

3. _____

4. _____

5. _____

POINTS TO REMEMBER

The Four Keys to Developing Persistence and Perseverance

1. Rekindle and re-fire your purpose and vision everyday. Draw daily inspiration from the rewards you will receive when your vision is realized.

2. Anchor the following attitude deep within you mind and heart: “With self-discipline I can achieve anything that I set my mind to, no matter how much hard work it takes, no matter how difficult it is, no matter how long it takes. I can and will achieve it.”
3. Realize that obstacles and setbacks will be set on your pathway as you strive to attain your purpose and vision. Realize that these difficulties are really opportunities from which you can learn new insights that will strengthen your resolve and increase your knowledge.
4. Turn your work into fun. Make what you have to do something you want to do.
 - Most people give up on their goals when they discover there is real work involved. Rather than dive right into the mainstream of work, they look for shortcuts. When they realize that the short cuts don’t work, they give up.
 - When you are faced with an obstacle or setback, believe that your problem can and will be solved—rather than surrender to failure.
 - Develop the courage and maturity to face your faults and weaknesses and then correct them.
 - Failure is only failure if you fail to learn from it.
 - The emotion you draw from your vision is the sustaining power of persistence and perseverance..

PROGRESS CHECK

1. Write a brief description of how you will develop the power of persistence and perseverance.

2. List and describe in your own words the five guidelines for turning a setback into a learning opportunity. Check your answer against what you wrote in the Practice section.

1. _____

2. _____

3. _____

4. _____

5. _____

3. The ultimate progress check is when you feel you can achieve anything you desire and achieve it with excellence through the power of self-discipline.

CONCLUDING THOUGHTS

The principles you learned in this program are based on powerful truths. They work! The only way you can achieve your heart's desire is by following these principles. There are no shortcuts or quick fixes tht will work for you. This program gives you the essential knowledge and tools you need to develop the incredible power of self-discipline.

Applied knowledge is power—and with his power you now possess the raw materials, master tools and skills to achieve anything to which you set your mind and direct your energy.

We wish success and joy in your efforts.